

THREE PHASE TRANSFORMER PAD SPECIFICATIONS

FIGURE 10A

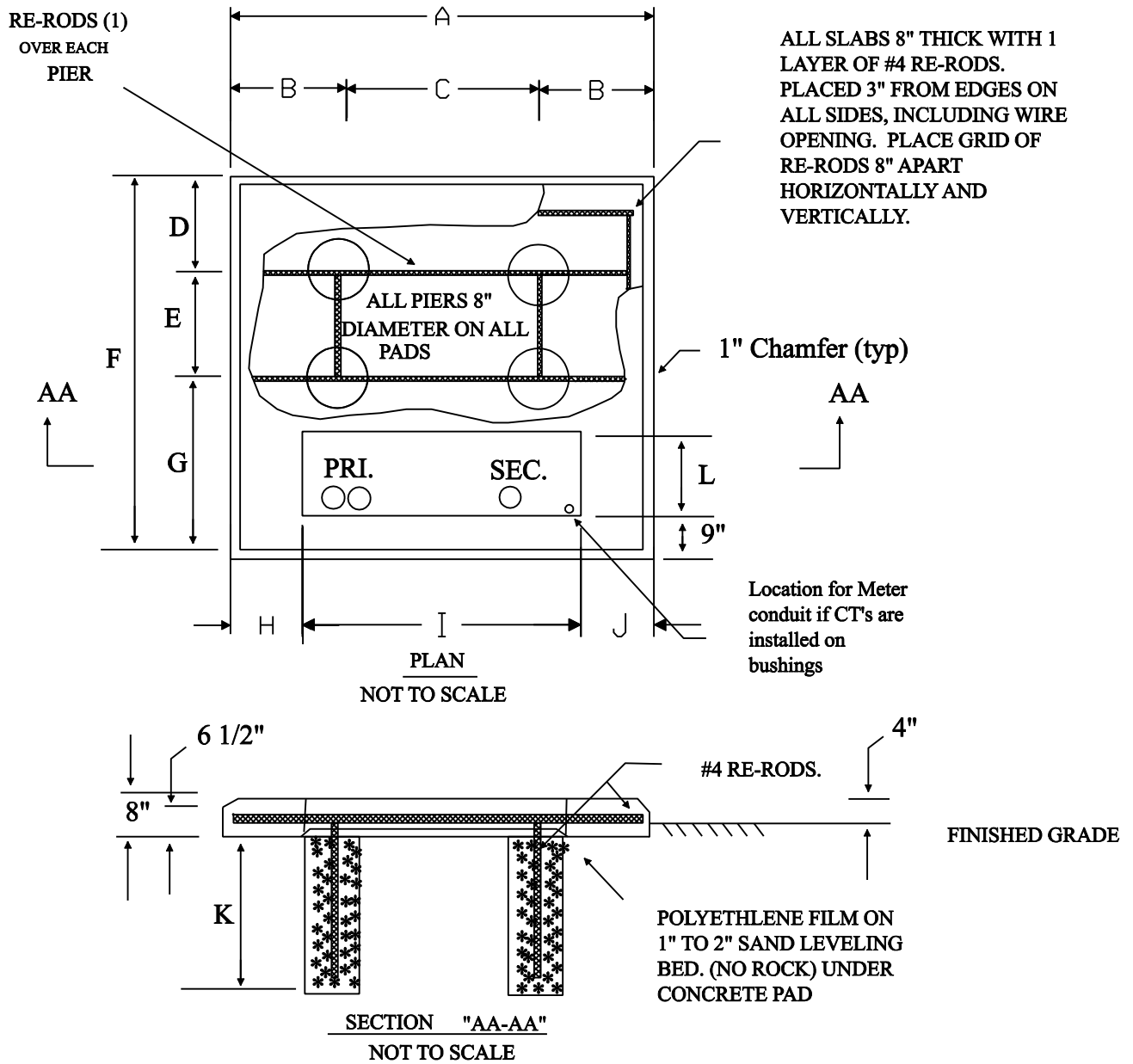

3-PHASE KVA	PAD DIMENSIONS											
	A	B	C	D	E	F	G	H	I	J	K	L
75-225KVA	7'-0"	18"	48"	12"	27"	5'-6"	27"	26"	40"	18"	48"	12"
225-500	7'-4"	20"	48"	24"	24"	6'-6"	30"	28"	45"	15"	60"	15"
750-1500	9'-0"	30"	48"	30"	44"	8'-8"	30"	27"	54"	27"	78"	15"

NOTES:

1. Top surface shall be a smooth plane. The maximum allowable variation in the height between any two points on this surface is 0.125 inches.
2. Three inch minimum concrete cover required over rebar on sides and around opening of foundation and 2" from surfaces (top and bottom).
3. 3000 lb. test concrete. ASTM A 615-40 reinforcing steel.
4. Guard post where required for traffic protection consist of rigid steel conduit concrete filled and embedded. Consult Utility for size, quantity and location of post.